

glass.
by gaviota

Climatika

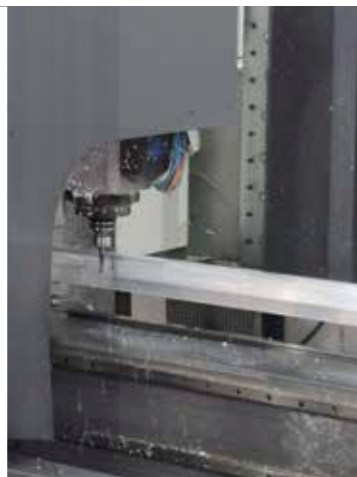







glass.

by gaviota

Glass by Gaviota est une nouvelle entreprise née pour accompagner et aider ses clients à contrôler le climat. Avec le soutien du groupe international Gaviota, il propose de maximiser la jouissance et le confort de l'habitat.

Les systèmes Glass by Gaviota sont conçus pour économiser l'énergie, protéger l'environnement, réduire l'empreinte carbone et l'impact sur la planète.

Le cycle de production est maîtrisé dès le début pour garantir votre satisfaction, utilisant la plus haute technologie et des matériaux les plus innovants.

Depuis 2021 Glass by Gaviota allie professionnalisme, transparence et protection dans les espaces extérieurs et intérieurs, basés sur des solutions bioclimatiques qui tirent le meilleur parti de l'apport de lumière naturelle. La marque combine des matériaux aussi adaptables que le verre et l'aluminium. Parmi sa gamme de produits étendue et ambitieuse, Climatika se démarque par des lignes droites et design contemporain, avec de nombreuses options de personnalisation.

Glass by Gaviota is a new company born to assist and help its customers to control the climate. With the backing of the international group Gaviota, it proposes to maximise the pleasure and comfort of the home.

Glass by Gaviota systems are designed to save energy, protect the environment, reduce the carbon footprint and the impact on the planet.

The production cycle is controlled, from the beginning to your satisfaction and all this with the highest technology and the most innovative materials

Since 2021, Glass by Gaviota has been combining professionalism, transparency and protection in interior and exterior spaces, based on bioclimatic solutions that maximise the most of natural light. The company combines adaptable materials such as glass and aluminium; Among its extensive and ambitious range of products, Climatika stands out, straight lines and contemporary design, with many customisation options.



Protection maximale avec un design élégant

Profitez de l'espace extérieur comme jamais auparavant. Créez de nouvelles ambiances et protégez-vous des intempéries. Maintenant, avec notre pergola Climatika, c'est possible. Peu importe qu'il fasse beau, pluvieux, froid ou chaud, vous décidez de la météo et de la façon dont vous voulez en profiter.

En plus de la fonctionnalité, du confort et de la durabilité, chez Glass, nous n'avons pas négligé le design. C'est pourquoi votre maison ne peut que s'améliorer avec nos produits. Mécanismes sophistiqués, intégrés et soucieux du design. Pour Glass, chaque détail compte.

Maximum protection with elegant design

*Enjoy the outdoors like never before.
Create new atmospheres and protect yourself from any weather conditions. Now with our Climatika pergola it is possible.
It doesn't matter if it's sunny, rainy, cold or warm, you decide your climate and how you want to enjoy it.*

*Besides functionality, comfort and sustainability, in Glass we have not left design aside. That's why with our products, your home can only win.
Sophisticated, integrated and design-conscious mechanisms. Because at Glass, every detail counts.*





AL Aluminium
Aluminium



Autoportante
Self-standing



Possibilité de fermeture périphérique
Perimeter enclosure option



Bicoloration Possible
Two-colour Option



Plat
Flat



Marcage CE
CE Marking



Restistance aux phénomènes atmosphériques
Weather Resistance



Intégration avec d'autres Systèmes Gaviota
Integration with other Gaviota Systems



Évacuation — Drainage

Profitez de la pluie sans vous mouiller.
Toute l'eau est collectée dans des gouttières
spécialement conçues et acheminée vers les égouts.

*Enjoy the rain without getting wet.
All the water is collected in the specially designed
gutters and is redirected to the drains.*



Choix du sens d'ouverture



Opening direction option

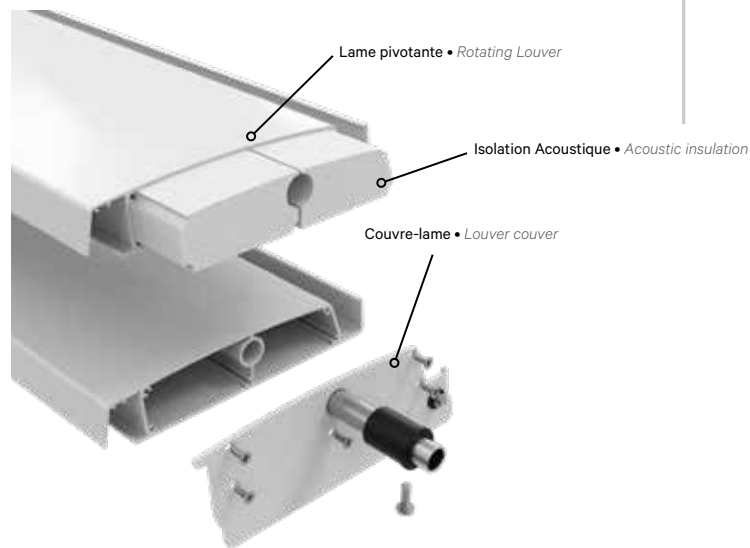
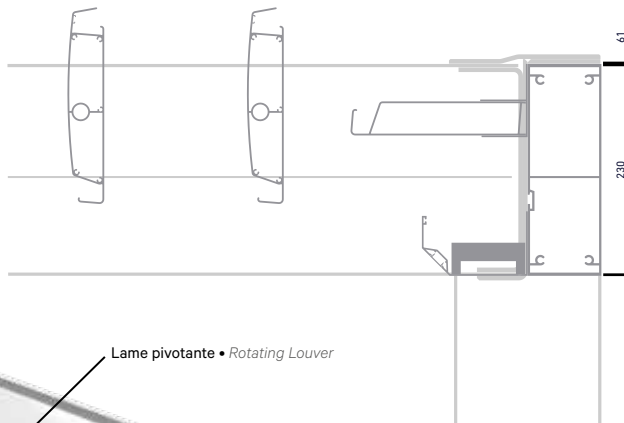

Lame pivotante

Climatika vous permet de contrôler votre climat par des lames rotatives sur le toit protégeant de la pluie ou de la neige pendant les mois les plus froids, et offrent une protection complète contre les rayons du soleil en été, et dans différentes positions d'ouverture, elles permettent la ventilation, circulation de l'air comme ainsi que le contrôle de la lumière du soleil.

Rotating Louver

Climatika allows you to control your climate, as the rotating louvres on the roof protect you from rain or snow in the coldest months, and provide full protection from the sun's rays in the summer, and in different open positions they allow ventilation and air circulation as well as sunlight control.

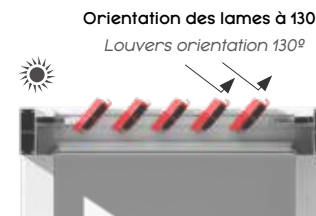
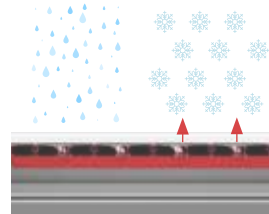
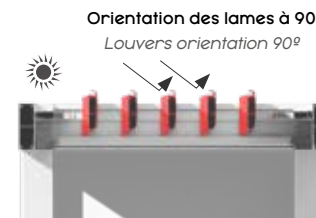
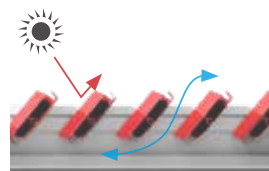
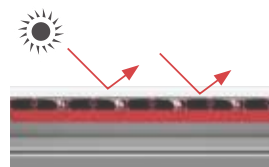
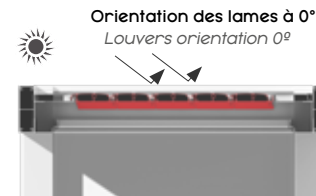



Profils — Profiles

Support de lame • Louver support Profil gouttière LED • Profile Gutter LED

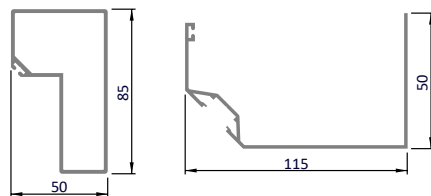

Support de lame fixe • Fixed Louver Support

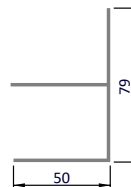

Profil Poteau • Column Profile

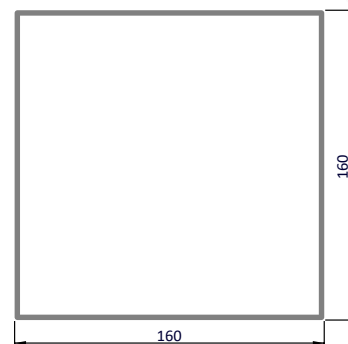

Lame fixe • Fixed Louver

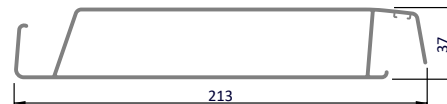

Lame Pivotante à Led • Rotating Louver LED

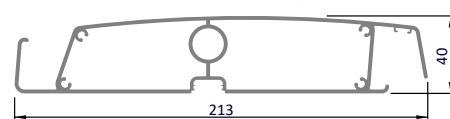

Lame Pivotante • Rotating Louver

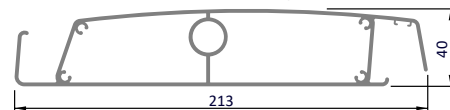

Profil poutre • Beam Profile Profil renfort de poutre
Reinforcement Beam Profile

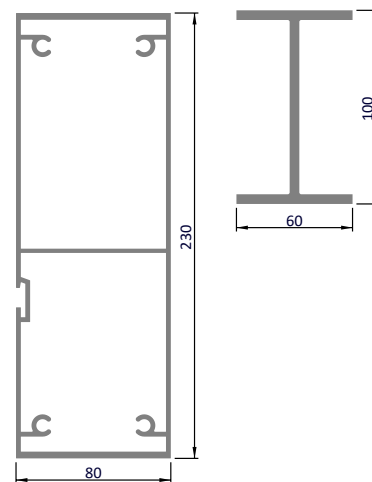

Mesures en mm • Measure in mm

Configurations Configurations

Module simple • Simple modules

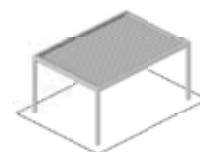

Autoportante
Self-standing

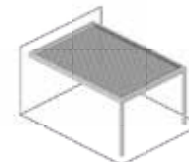

Adossée lame parallèle au mur
On facade Louvers parallel to the wall

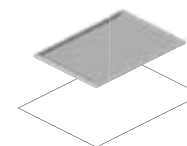

Entre-murs
Between walls



Adossée lame perpendiculaire au mur
On facade Louvers perpendicular to the wall

Module multiple • Multiple modules

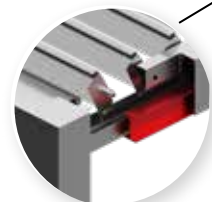
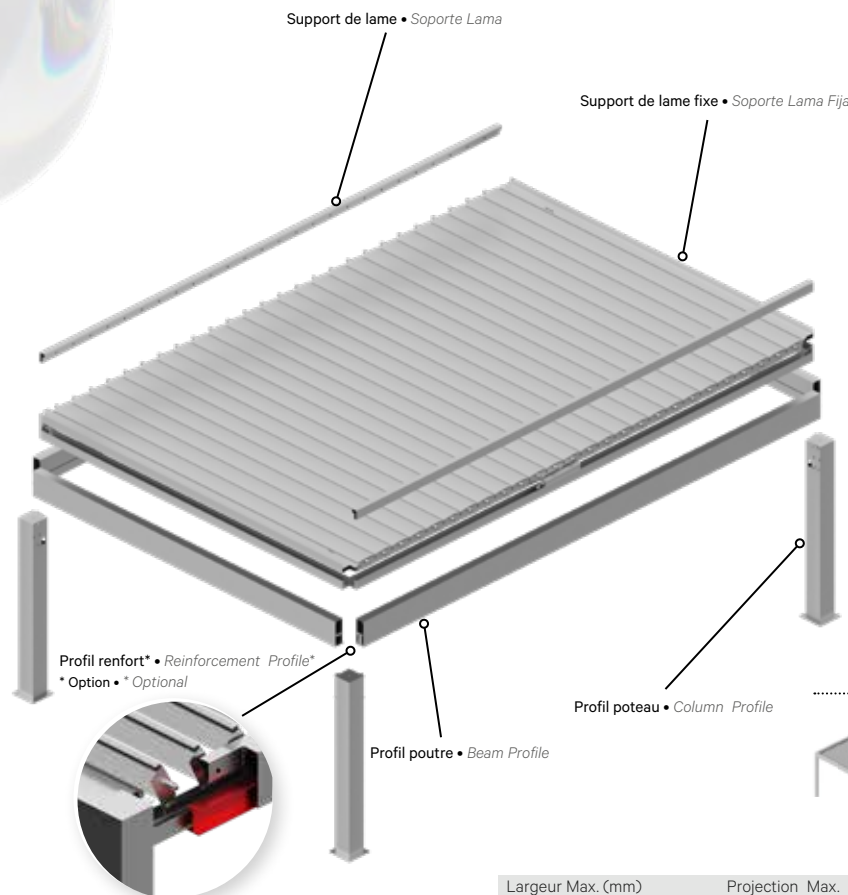
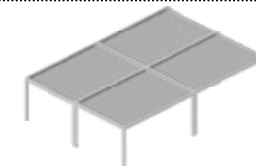

- Autoportante
Self-standing
- Adossée lame parallèle au mur
On facade Louvers parallel to the wall
- Adossée lame perpendiculaire au mur
On facade Louvers perpendicular to the wall
- Entre-murs
Between walls

Largeur Max. (mm) Max. Width (mm)	Projection Max. (mm) Max. Projection (mm)	Largeur de poteau (mm) Column size (mm)	Manœuvre Operation	Classe au vent UNE-EN13561 Wind class UNE-EN 13561
4200	6000	160x160	Motor	6
4200	6000	160x160	Motor	6
6000	4200	160x160	Motor	6
4200	6000	NO	Motor	6

nouveauté!

inew!

Climatika Plus

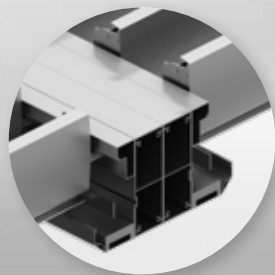

Section Poutres Centrales
Central Beams Section

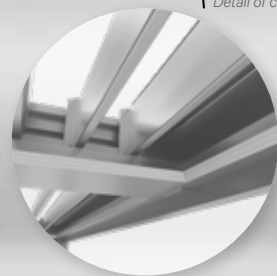

Détail de jonction entre poutre centrale et poutre Plus
Detail of connection between Central Beams and Plus Beam

Dimensions maximales
Maximum dimensions

Largeur Maxi (mm)
Width L (mm)

7000

Projection Maxi (mm)
Projection S (mm)

6000

Section —
Section

Profil poutre Plus • Beam Plus profile

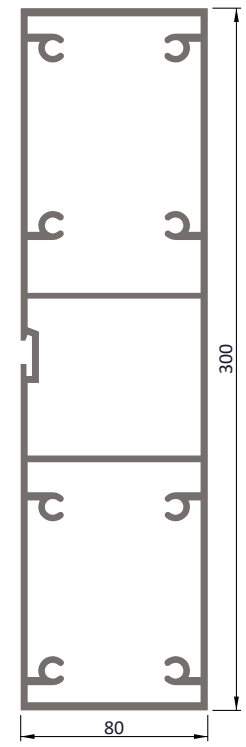

Eclairage Led __

Créez votre propre ambiance, de jour comme de nuit!

Choisissez avec des possibilités de personnalisation infinies!

- Bandes LED intégrées en périphérie de la structure : dans les couleurs programmables vous pouvez choisir entre lumière blanche ou RGB colorée.
- Bandes LED intégrées dans la lame : vous avez le choix entre lumière blanche ou RVB coloré.
- Spots LED intégrés dans la lame : vous avez le choix entre 4 ou 8 spots.

LED lights

Create your own ambience, day or night!

You choose how with endless personalisation possibilities!

- LED strips integrated in the perimeter of the structure: you can choose between white light or programmable coloured RGB.
- LED strips integrated in the slat: you can choose between white or coloured RGB light.
- LED spots integrated in the slat: you can choose between 4 or 8 spots.







Domotique —

Envie de soleil et de vent ou d'une protection complète ?

Ouvrez et fermez les lames en un seul clic et quelques secondes, grâce au nouveau moteur le plus rapide et silencieux du marché. Vous pouvez le faire à la fois avec la télécommande et avec votre smartphone.

Home automation

Do you want sun and breeze or full protection?

Opens and closes the louvers with a single click in seconds, thanks to the fastest and quietest new motor on the market. And you can do it both with the remote control and with your mobile phone.

Emetteur et récepteur —

Remote control and receiver



Moteur de bras hydraulique
Hydraulic arm motor



Récepteur central
Central receiver



Emetteur 6 canaux
Remote control 6 channels

Tout en un sur une seule télécommande:

- Contrôlez la fermeture et ouverture des lames.
- Contrôlez l'éclairage périphérique et des lames.
- Contrôlez les systèmes verticaux grâce à une centrale adaptée.

All in 1 from the same remote control:

- Control the louvers opening and closing.
- Control perimeter and louvers lighting.
- Control vertical systems thanks to the special control unit

Capteurs —

Avec les systèmes domotiques et les capteurs de dernière génération, inutile de vous préoccuper, ils vous aident à tout moment à créer un climat parfait et à protéger votre pergola.

Sensors

You don't have to worry about anything with home automation systems and high-tech sensors that help you create the perfect climate and protect your pergola at any moment

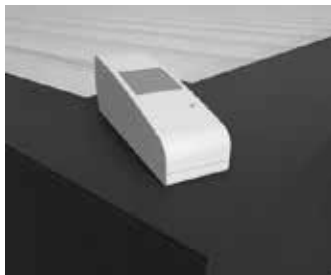

Accessoires et connectivité —

Accessories and connectivity



Capteur de Pluie
The rain sensor

Le capteur de pluie vous donne l'assurance que même une goutte d'eau ne peut vous empêcher de profiter de votre pergola. Profitez de la pluie comme jamais auparavant.

The rain sensor gives you the security that not even a drop of water can stop you from enjoying your pergola. Enjoy the rain like never before.



Capteur Vent
The wind sensor

Le capteur vent agit par vent fort et ouvre les lames afin que la structure ne subisse aucun dommage. Le capteur de vent est prioritaire sur le capteur pluie.

The wind sensor acts in the case of a strong wind and opens the louvers so that the structure does not suffer any damage. The wind sensor takes over the rain sensor.



Système de Son Bluetooth
Bluetooth sound system.

Vous aimez la musique et n'imaginez pas votre vie sans elle ? Ne vous inquiétez pas, vous pouvez maintenant en profiter même à l'extérieur avec notre système de son Bluetooth.

Do you love music and can't imagine your life without it? Don't worry, now you can enjoy it even outdoors with our bluetooth sound system.



APP Apple et Android
APP Apple and Android

Imaginez-vous pouvoir ouvrir et fermer les lames, allumer ou éteindre les lumières en variant les couleurs RGB avec votre smartphone ? Tout est possible avec l'APP.

Can you imagine being able to open and close the louvers, turn the lights on or off and even change the colour of the RGB lighting with just your mobile phone? It's all possible with the APP.

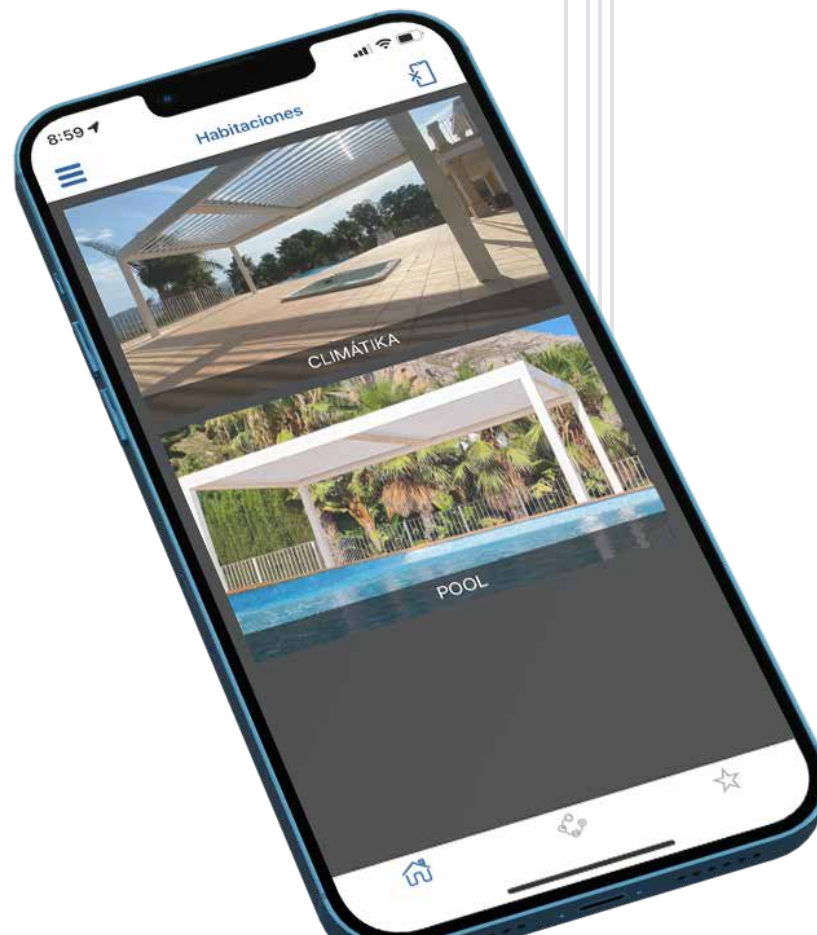



Certification

La Climatika respecte les normes de sécurité les plus élevées et est homologuée en classe 6 de résistance au vent dans ses dimensions maximales d'un module de 4,2 x 6 x 3m, selon la norme européenne UNE-EN 1932:2014

Auvents et stores. Comprend aussi le calcul structurel selon UNE EN 13561, UNE EN 1993-1-8, UNE ENV 1991-2-4 et le Code Technique, obtenant les résultats suivants:

Certification

Climatika complies with the highest safety standards and is approved in Class 6 of wind resistance in its maximum measures of a module of 4.2 x 6 x 3m according to European standard UNE-EN 1932:2014. Awnings and blinds.

It has the structural calculation according to the UNE EN 13561, UNE EN 1993-1-8, UNE ENV 1991-2-4 and the Technical Code, obtaining the following results:

Estructura • Structura			
Configuration <i>Configuration</i>	Vitesse du vent <i>Wind speed</i>	Pression statique équivalente <i>Equivalent static pressure</i>	Charge de neige <i>Snow loading</i>
Pont fermé <i>Closed deck</i>	47,8 km/h	110Pa	
Pont ouvert <i>Open deck</i>	128,8 km/h	800Pa	65kg/m2

REMARQUE: Les résultats des tests de résistance au vent ont été obtenus avec les produits fabriqués par Gaviota Simbac qui sont détaillées dans les rapports d'essais correspondants.

NOTE: The results of the wind resistance tests have been obtained with the products manufactured by Gaviota Simbac which are specified in the corresponding test reports.



glass.
by gaviota



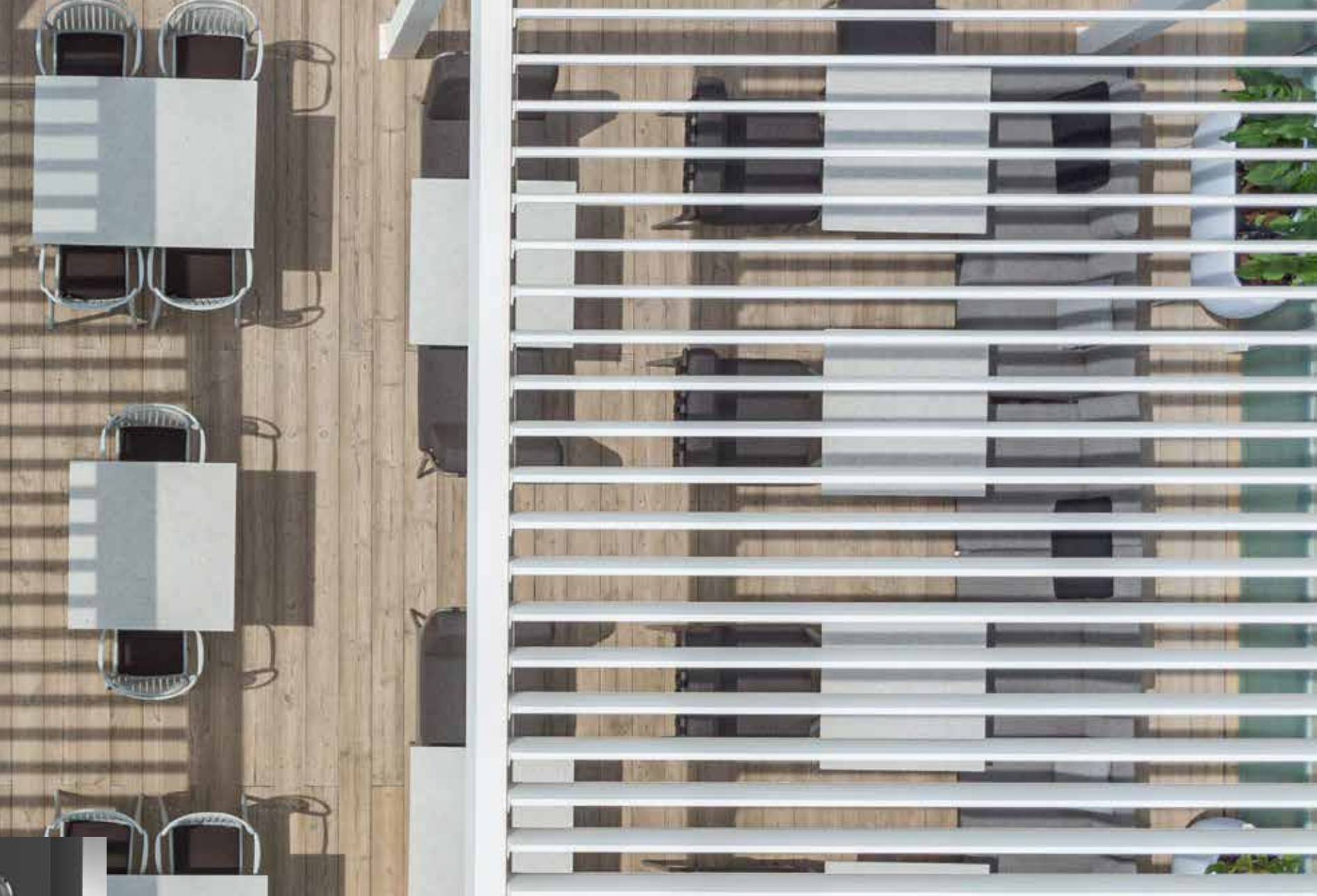

Palette de couleur __
Colour Chart



Blanc Gaviota
Gaviota White



Bronze Texturé
Textured Bronze



Gris 7016 Texturé
Textured Grey 7016



Blanc Texturé
Textured White



Noir Texturé
Textured Black

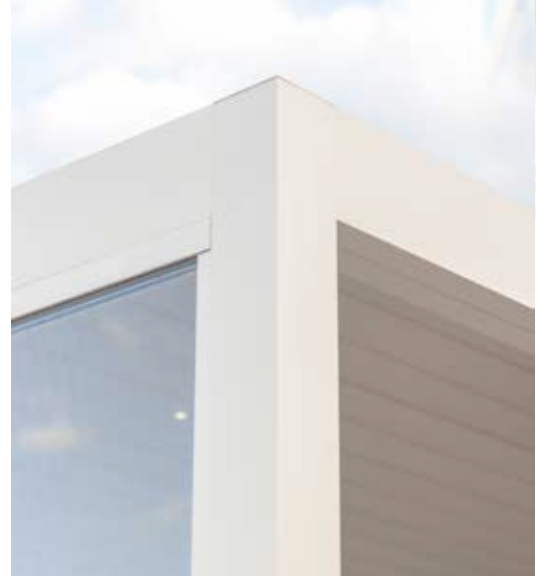

Argent Texturé
Textured Silver



Marron 8014
Brown 8014



Beige 1013
Beige 1013



Ral Spécial
Special Ral

Personnalisez votre Climatika en choisissant la couleur de la structure et des lames.
Vous pouvez aussi combiner 2 couleurs si vous le souhaitez. Si vous préférez une autre couleur, consultez notre Nuancier RAL.

*Personalise your Climatika and choose the colour of the structure and the louver.
You can even combine 2 colours if you want. And if you prefer another colour, consult our RAL chart.*

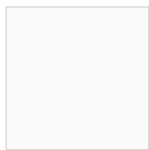

40100407

Ultra Mate Bianco TG

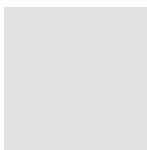

40100411

Ultra Mate Silver Anodizado



40100414

Ultra Mate Griggio Classico



40100409

Ultra Mate Marino



40100410

Ultra Mate Gold



40100412

Ultra Mate Terra



40100408

Ultra Mate Vino



40100415

Ultra Mate Marrone



40100413

Ultra Mate Nero Anodizado

